



PMB 6272

SMARTi PM

SMARTi PM (PMB 6272) is a low-cost, highly integrated quad-band single chip CMOS transceiver for GSM850/GSM900/GSM1800/GSM1900 voice and high performance data transfer applications.

THE TRANSCEIVER IS DESIGNED for lowest power consumption, and provides an analog I/Q baseband interface, a Zero IF direct conversion receiver and a quad-band polar modulator for EDGE with integrated PGA functionality.

FURTHER ON IT COMPRISES a completely integrated digital $\Sigma\Delta$ -synthesizer with HSCSD and GPRS/EDGE capability, a digitally controlled reference oscillator with three outputs and a fully integrated quad-band RF oscillator (VCO). The Universal I/Q Interface and three wire bus, fit to Infineon and all common basebands available on the market.

THE OPTIMIZED ARCHITECTURE of the SMARTi PM ensures an easy-to-use EDGE solution enabling a very size effective RF Engine implementation.

Features

- Receiver
 - Direct conversion receiver optimized for 72 dB dynamic range ADC RX baseband interface
 - Automatic DC offset compensation
 - Very low power budget
 - GPRS/EDGE class 1 to 12
- Transmitter
 - Polar modulator for EDGE
 - Single-ended 50 Ω outputs enable direct connection with Power Amplifier
 - PA bias control interface for efficiency EDGE enhancement of contemporary linear EDGE-Power Amplifier
 - Programmable Gain Amplifier (PGA) for accurate output power level control in 8PSK mode
 - Integrated ramping generator for 8PSK mode
 - Integrated low tolerance base band filter
 - Very low power budget
 - GPRS/EDGE class 1 to 12
- RF-Synthesizer
 - $\Sigma\Delta$ -synthesizer for multi-slot operation supports GPRS/EDGE (class 1 to 12)
 - Fast lock-in times (<150 μ s)
 - Integrated loop filter
- RF Oscillator
 - Fully integrated, low noise RF VCO for quad-band operation
- Reference Oscillator
 - Fully integrated VCXO
 - Fully digital controlled crystal oscillator core with highly linear tuning characteristic
 - 26 MHz Reference Oscillator can be applied externally
 - Three single ended clock outputs
- Baseband interface
 - Multiplexed differential I/Q baseband TX-input voltages and RX-output voltages
 - Three wire bus for transceiver control
- Frontend module interface
 - Two FEM control outputs
- Ultra Low RF BOM < 20 components needed

www.infineon.com/mobilesolutions

Mobile Solutions



Never stop thinking.

Infinion GSM/EDGE Quad-Band Solution using SMARTi PM (PMB 6272), S-GOLD2 (PMB 8876) and SM-POWER3 (PMB 6821)

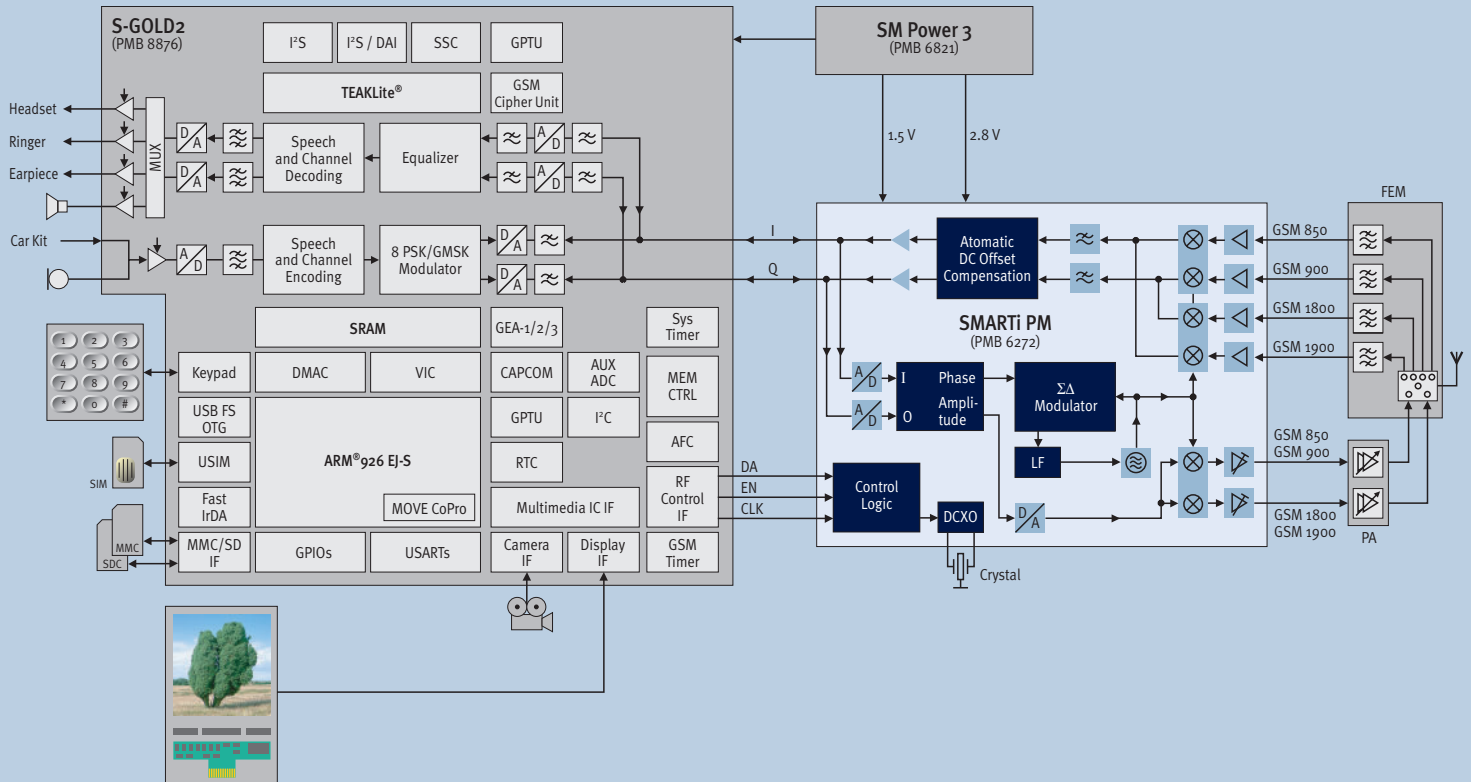

Applications

- GSM/EDGE single, dual, triple, and quad band Mobile Phones and Data Modems / PC cards

Technology

- Based on Infineon's C11 0.13 μm RF-CMOS Technology
- Supply voltage 1.4 V ... 1.6 V and 2.7 V ... 2.9 V
- VQFN-40 green package (5.5 x 6.5 mm²)

Note: TEAKLite® is a registered trademark of ParthusCeva, Ltd.
ARM® is a registered trademark of ARM, Ltd.

How to reach us:
<http://www.infineon.com>

Published by
Infineon Technologies AG
St.-Martin-Strasse 53
81669 München

© Infineon Technologies AG 2004.
All Rights Reserved.

Template: pb_w_tmplt.fm/2

Attention please!

The information herein is given to describe certain components and shall not be considered as a guarantee of characteristics. Terms of delivery and rights to technical change reserved.

We hereby disclaim any and all warranties, including but not limited to warranties of non-infringement, regarding circuits, descriptions and charts stated herein.

Information

For further information on technology, delivery terms and conditions and prices please contact your nearest Infineon Technologies Office.

Warnings

Due to technical requirements components may contain dangerous substances. For information on the types in question please contact your nearest Infineon Technologies Office.

Infineon Technologies Components may only be used in life-support devices or systems with the express written approval of Infineon Technologies, if a failure of such components can reasonably be expected to cause the failure of that life-support device or system, or to affect the safety or effectiveness of that device or system. Life support devices or systems are intended to be implanted in the human body, or to support and/or maintain and sustain and/or protect human life. If they fail, it is reasonable to assume that the health of the user or other persons may be endangered.

Ordering No. B134-H8541-X-X-7600
Printed in Germany
PS 010515 nb